

Compressed Air Distribution Networking

Comparison of Compressed Air Distribution Networks: the advantage of Metal Work

The compressed air network is vital in many industrial sectors, from factories to workshops.

The choice of material for the pipes in this network plays a crucial role in the efficiency and reliability of the system. Among common materials, such as steel and plastic, aluminum emerges as an option with several differentiators. Aluminum pipes stand out for their compatibility with modern monitoring and control systems. Its smooth surface and corrosion resistance ensure reliable operation, even in environments where precision and automation are essential.

Durability and Resistance:

Metal Work Pipes are made from aluminum and, for this reason, are recognized for their exceptional durability and resistance. Unlike steel, they do not corrode, even in humid or aggressive environments. This ensures a longer System life, reducing long-term maintenance and replacement costs.

Weight and Easy Installation:

Metal Work fittings are also made of aluminum and are therefore lighter than those developed in steel and due to their constructive design, making the pipes installation easier and faster, without tools to shape the tube, reducing assembly time by up to 8x.

Flexibility and Adaptability:

Aluminum piping offers excellent flexibility, allowing for curves and contours that would be difficult or impossible with steel piping. This simplifies layout and can reduce the need for additional fittings, minimizing potential leak points.

Energy Efficiency:

The Metal Work fitting, due to its construction model has a higher thermal conductivity than steel, which means that energy losses, due to compressed air cooling, are lower in aluminum piping systems. This translates into significant energy savings over time, contributing to sustainability and reducing operating costs.

In summary, the Metal Work Compressed Air Distribution Network offers a number of significant advantages compared to other manufacturers. Its durability, light weight, easy installation, flexibility and energy efficiency make it an ideal choice for companies looking to maximize the performance of their systems, while reducing long-term operating and maintenance cost.

INDEX

COMPRESSED AIR DISTRIBUTION NETWORK COMPONENTS	5	BYPASS – Ø25	11
SOLUTIONS	5	BYPASS – Ø20	11
DATA SHEETS	5	FIXING TO BEAMS AND WALLS	12
COMPONENTS	6	AERIAL FIXING	12
COMPONENTS - ELBOW FITTINGS FOR PIPES (Ø63/Ø50/Ø40/Ø32/Ø25)	6	BALL VALVE CONNECTION COMPONENTS (Ø63/Ø50/Ø40 / Ø32 / Ø25)	13
ELBOW FITTINGS Ø63	6	BALL VALVE CONECTION COMPONENTS (Ø25 / Ø20)	13
ELBOW FITTINGS Ø40	6	KRDA6363 – FLANGE FITTINGS Ø63 / TUBE Ø63	13
COMPONENTS - ELBOW FITTINGS FOR PIPES (Ø25/Ø20)	6	KRDA6312 – FLANGE FITTINGS Ø63 WITH FEMALE THREAD OUTLET G1/2	13
ELBOW FITTINGS Ø25 / Ø20	7	KRDA4040 – FLANGE FITTINGS Ø40 / TUBE Ø40	14
COMPONENTS - TEE FITTINGS FOR PIPES (Ø63/Ø50/Ø40/Ø32/Ø25)	7	KRDA4032 – FLANGE FITTINGS Ø40 / TUBE Ø32	14
TEE FITTINGS Ø63	7	KRDA4025 – FLANGE FITTINGS Ø40 / TUBE Ø25	14
TEE FITTINGS Ø40	7	KRDA4012 – FLANGE FITTINGS Ø40 WITH FEMALE THREAD OUTLET G1/2	14
COMPONENTS - TEE FITTINGS (Ø25/Ø20)	8	KRDA2525 – FLANGE FITTINGS Ø25 / TUBE Ø25	15
COMPONENTS - TEE FITTINGS FOR PIPES WITH REDUCTION IN MM	8	KRDA2525 – FLANGE FITTING Ø25 / TUBE Ø20	15
TEE FITTINGS Ø25	8	KRDA2538 – FLANGE FITTINGS Ø25 WITH FEMALE THREAD OUTLET G3/8	15
COMPONENTS - STRAIGHT FITTINGS FOR PIPES (Ø63/Ø50/Ø40/Ø32/Ø25)	8	NIPPLE FOR STRAIGHT FITTINGS	15
STRAIGHT FITTINGS Ø63	9	ASSEMBLY INSTALLATION	16
STRAIGHT FITTINGS Ø40	9	NIPPLE FOR STRAIGHT FITTINGS WITH BALL VALVE	16
COMPONENTS - STRAIGHT FITTINGS FOR PIPES (Ø25/Ø20)	9	NIPPLE FOR BALL VALVE	16
STRAIGHT FITTINGS Ø25/Ø20	9	ALUMINIUM PIPING IDENTIFICATION	16
STRAIGHT FITTINGS Ø25 WITH FEMALE THREAD	10	ELEMENTS CUTTING 17	17
STRAIGHT PIPES	10	FIXING - MOUNTING BRACKETS IN THE HORIZONTAL OR VERTICAL DIRECTIONS	18
BYPASS 180° – Ø25	10	INSTALLATION AND ACCESSORIES ASSEMBLY	19
BYPASS 180° – Ø20	10	WARNING AND WARRANTY	22

COMPRESSED AIR DISTRIBUTION NETWORK

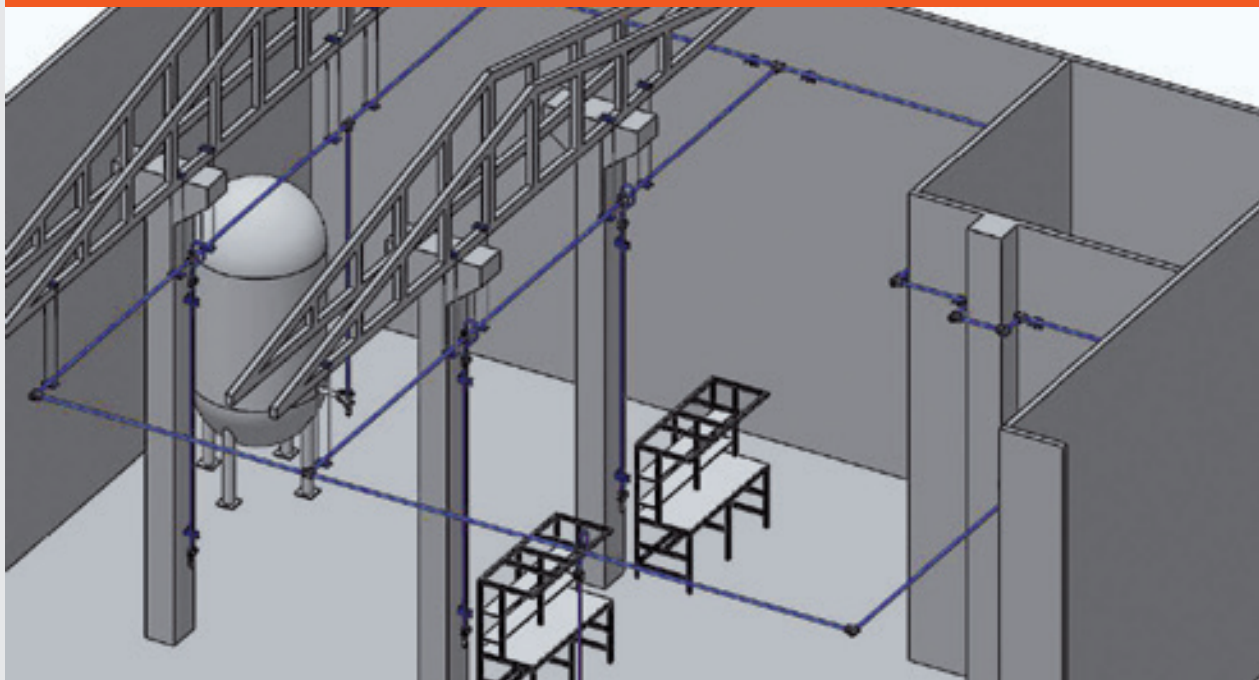

- Up to 16 bar working pressure
- Easy installation
- Injected aluminum fittings
- No special tools required for installation
- Quick maintenance

- Factory externally painted piping
- Main network diameters: $\text{Ø}63$ / $\text{Ø}50$ / $\text{Ø}40$ / $\text{Ø}32$
- Secondary network diameters: $\text{Ø}25$ / $\text{Ø}20$
- Compatible with the entire pneumatic line of Metal Work products

DATA SHEET

- Working pressure range from -0,99 to 16 bar
- Temperature range from -10 to 60 °C
- High mechanical resistance
- Low maintenance
- Easy installation
- Aluminum product
- Quick connect
- Project prepared based on the ASME standard

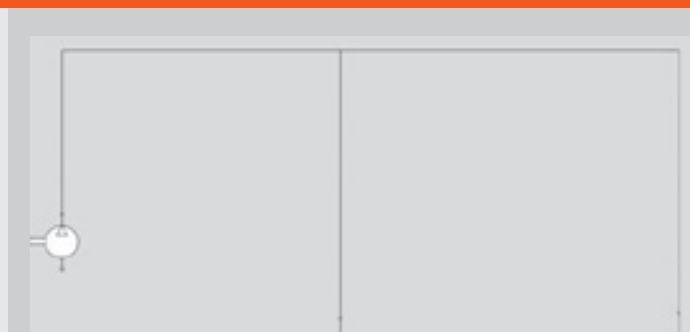

DETERMINATION OF THE INTERNAL Ø OF THE PIPE VIA NOMOGRAM

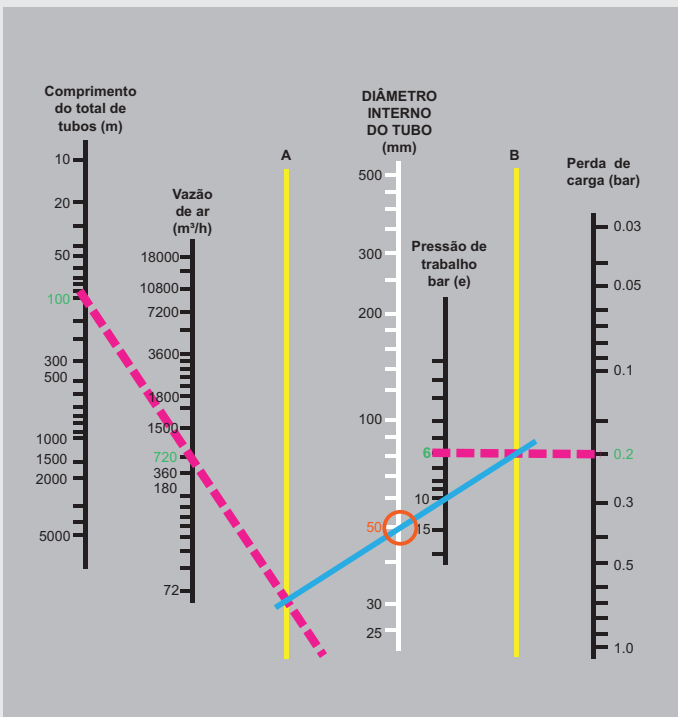
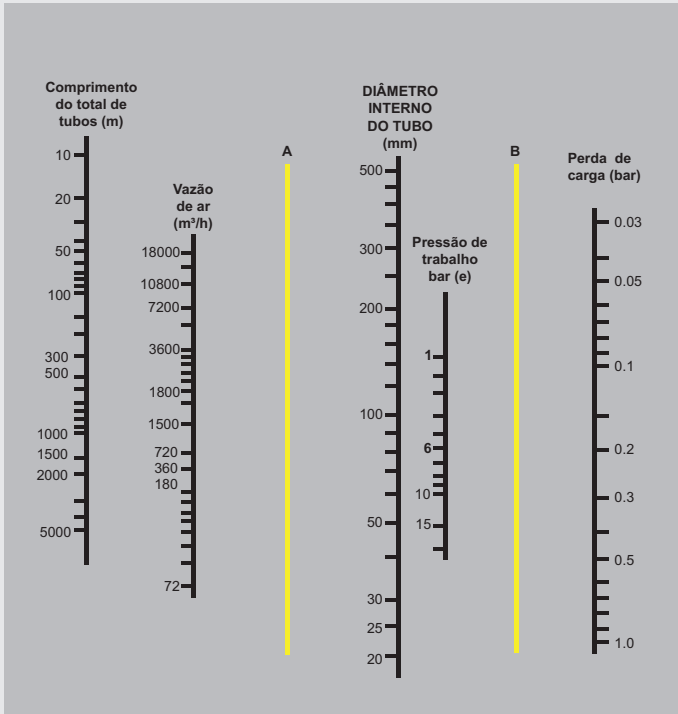

1. On the SECTION LENGTH scale, mark a point on the equivalent length of the network you need to determine;

2. On the AIR FLOW scale, mark a point on the average air flow compressed air flowing through the piping;

3. Connect the two points with a straight line to COLUMN A;

4. On the WORKING PRESSURE scale, repeat operation 1;

5. On the LOAD LOSS scale, repeat operation 2;

6. Repeat operation 3 on the WORKING PRESSURE and LOSS OF LOAD, but in COLUMN B;

7. Draw a straight line between the two points of COLUMN A and COLUMN B;

8. The intersection of this straight line drawn BLUE line between AXIS 1 and AXIS 2 will indicate the internal Ø sought;

EXAMPLE:

Pipe length: 100 meters

Average compressed air flow: 720 m³/h

Initial pressure: 6 bar

Desired pressure loss: 0.20 bar

Internal diameter of the pipe: In this example Ø 50, pipe of external Ø 60mm.

COMPRESSED AIR DISTRIBUTION NETWORK FITTINGS COMPONENTS

ELBOW FITTINGS FOR PIPES (Ø63/Ø50/Ø40/Ø32/Ø25)

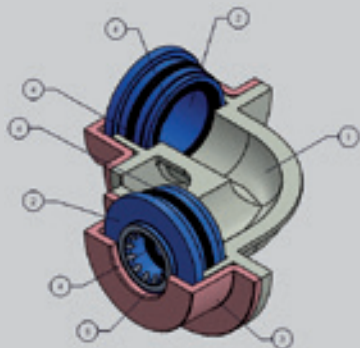

- ① FITTING - Aluminum
- ② SUPPORTING RING - Aluminum
- ③ FLANGE - Aluminum
- ④ SEAL - NBR
- ⑤ CLAMPING SPRING - Stainless steel

ELBOW FITTINGS Ø63

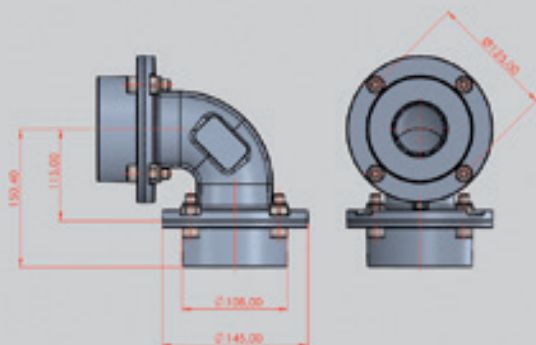

Code	Descrição
Z54RDACC6363	Elbow fitting - Ø63mm - 1,80Kg
Z54RDACC6350	Elbow fitting reduction for pipes Ø63mm-Ø50mm
Z54RDACC6340	Elbow fitting reduction for pipes Ø63mm-Ø40mm
Z54RDACC5050	Elbow fitting Ø50mm
Z54RDACC5040	Elbow fitting reduction for pipes Ø50mm-Ø40mm

ELBOW FITTINGS Ø40

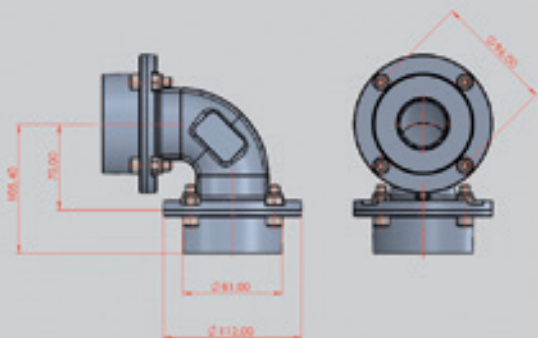

Code	Description
Z54RDACC4040	Elbow fitting Ø40mm - 0,80Kg
Z54RDACC4032	Elbow fitting reduction for pipes Ø40mm-Ø32mm
Z54RDACC4025	Elbow fitting reduction for pipes Ø40mm-Ø25mm
Z54RDACC40R0	Elbow fitting 1x Ø40mm 1x G.1/2"
Z54RDACC3232	Elbow fitting Ø32mm
Z54RDACC3225	Elbow fitting reduction for pipes Ø32mm-Ø25mm
Z54RDACC32R0	Elbow fitting 1x Ø32mm 1x G.1/2" Female

ELBOW FITTINGS COMPONENTS FOR PIPES (Ø25/Ø20)

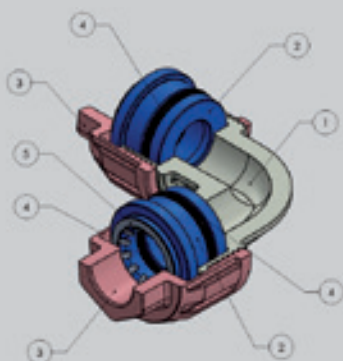

- ① FITTING - Aluminum
- ② SUPPORTING RING - Aluminum
- ③ THREADED FLANGE - Aluminum
- ④ SEAL - NBR
- ⑤ CLAMPING SPRING - Stainless steel

ELBOW FITTINGS Ø25, Ø20

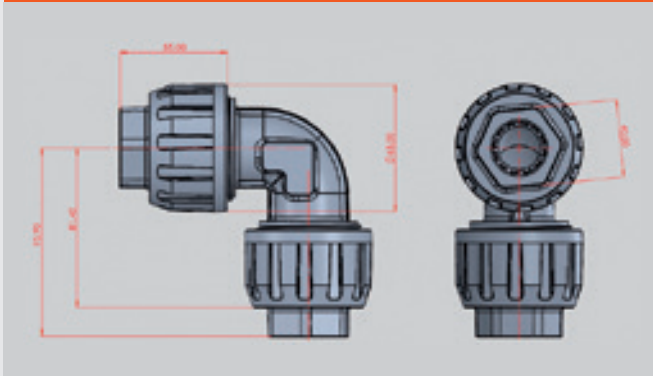

Code	Description
Z54RDACC2020	Elbow fitting Ø20mm
Z54RDACC2525	Elbow fitting Ø25mm - 0,37Kg Female
Z54RDACC2520	Elbow fitting reduction for pipes Ø25mm-Ø20mm
Z54RDACC20RO	Elbow fitting 1x Ø20mm 1x G.1/2" Female
Z54RDACC25RO	Elbow fitting 1x Ø25mm 1x G.1/2"

TEE FITTINGS COMPONENTS FOR PIPES (Ø63/Ø50/Ø40/Ø32/Ø25)

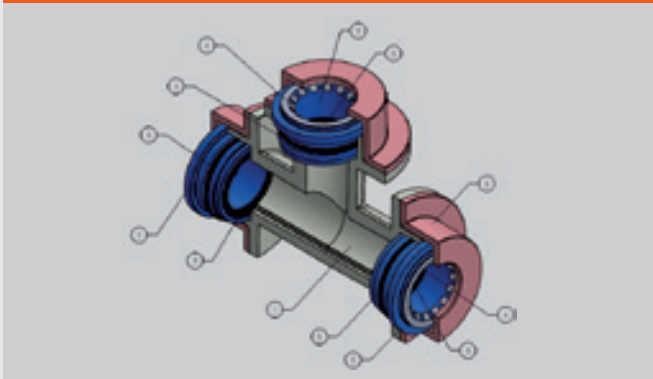

- ① FITTING - Aluminum
- ② SUPPORTING RING - Aluminum
- ③ FLANGE - Aluminum
- ④ CLAMPING SPRING - Stainless steel
- ⑤ SEAL - NBR

TEE FITTINGS Ø63

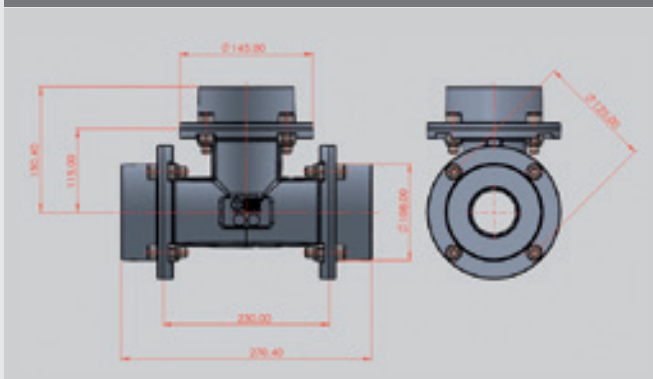

Code	Description
Z54RDACT6363	Tee fitting Ø63 - 2,65Kg
Z54RDACT6350	Tee fitting with reduction of 2x Ø63mm - 1x Ø50mm
Z54RDACT6340	Tee fitting with reduction of 2x Ø63mm - 1x Ø40mm
Z54RDACT5050	Tee fitting Ø50
Z54RDACT5040	Tee fitting with reduction 2x Ø50mm - 1x Ø40mm

TEE FITTINGS Ø40

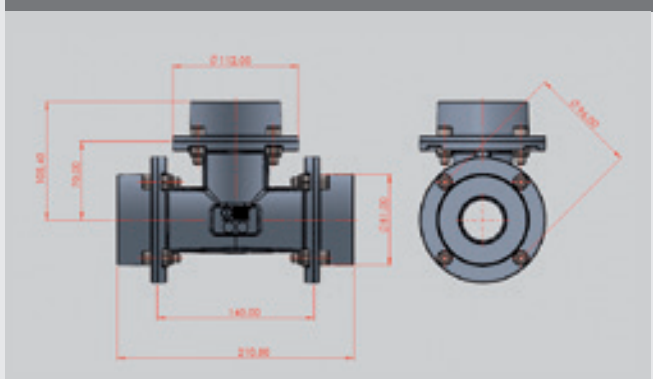

Code	Description
Z54RDACT3225	Tee fitting with reduction 2x Ø32mm - 1x Ø25mm
Z54RDACT3232	Tee fitting for pipes of Ø32mm
Z54RDACT32RO	Tee fitting 2x Ø32mm - 1x G.1/2", female
Z54RDACT4025	Tee fitting with reduction 2x Ø40mm - 1x Ø25mm
Z54RDACT4032	Tee fitting with reduction 2x Ø40mm - 1x Ø32mm
Z54RDACT4040	Tee fitting for pipes of Ø40mm
Z54RDACT40RO	Tee fitting 2x Ø40mm - 1x G.1/2" female

COMPRESSED AIR DISTRIBUTION NETWORK FITTINGS COMPONENTS

TEE FITTINGS COMPONENTS (Ø25/Ø20)

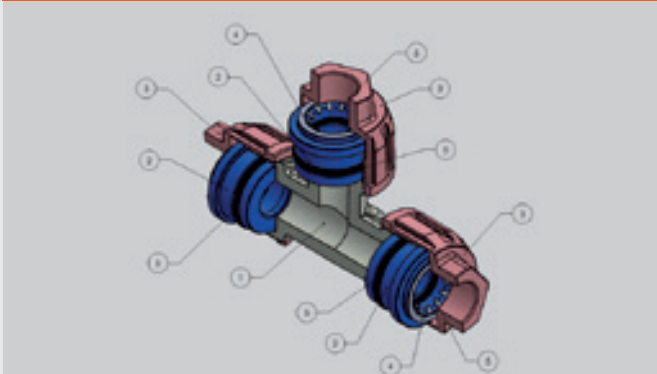

- ① FITTING - Aluminum
- ② SUPPORTING RING - Aluminum
- ③ THREADED FLANGE - Aluminum
- ④ CLAMPING SPRING - Stainless steel
- ⑤ SEAL - NBR

TEE FITTINGS COMPONENTS FOR PIPE WITH REDUCTION (MM)

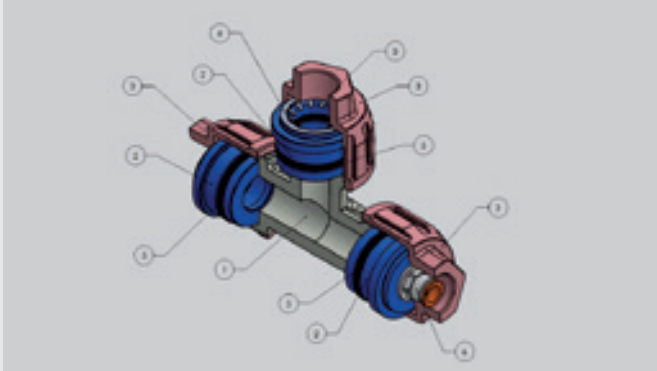

- ① FITTING - Aluminum
- ② SUPPORTING RING - Aluminum
- ③ THREADED FLANGE - Aluminum
- ④ CLAMPING SPRING - Stainless steel
- ⑤ SEAL - NBR
- ⑥ FITTING - Brass

TEE FITTINGS Ø25

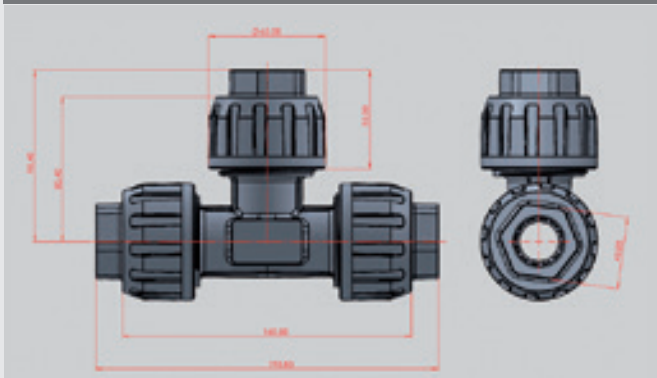

Code	Description
Z54RDACT2020	Tee fitting Ø20 - 0,53Kg
Z54RDACT2025	Tee fitting with reduction 1x Ø25mm - 2x Ø20mm
Z54RDACT2525	Tee fitting Ø25 - 0,53Kg
Z54RDACT2520	Tee fitting with reduction 2x Ø25mm - 1x Ø20mm
Z54RDACT20RO	Tee fitting female 2x Ø20mm 1x G.1/2"
Z54RDACT25RO	Tee fitting female 2x Ø25mm 1x G.1/2"
Z54RDACTRO20	Tee fitting female 2x G.1/2" 1x Ø20mm
Z54RDACTRO25	Tee fitting female 2x G.1/2" 1x Ø25mm

STRAIGHT FITTINGS FOR PIPES (Ø63/Ø50/Ø40/Ø32/Ø25)

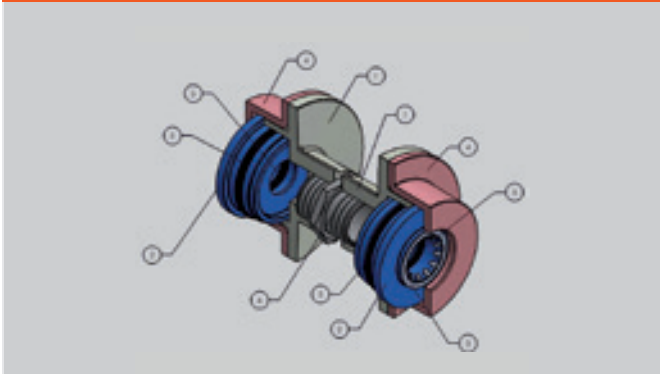

- ① STRAIGHT FITTING - Aluminum
- ② SUPPORTING RING - Aluminum
- ③ FLANGE - Aluminum
- ④ CLAMPING SPRING - Stainless Steel
- ⑤ SEAL - NBR
- ⑥ NIPLÉ - Aluminum

STRAIGHT FITTINGS Ø63

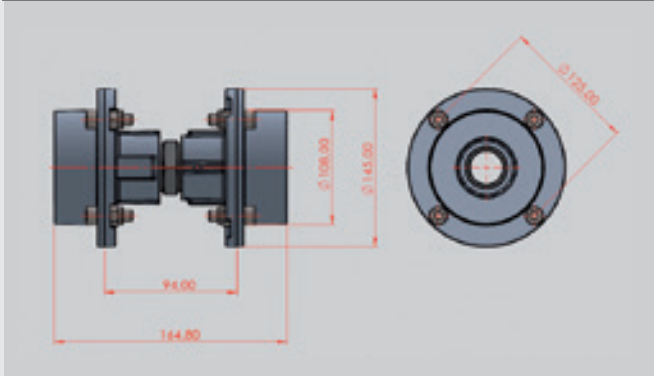

Code	Description
Z54RDACR6363	Straight Fitting Ø63mm - 0,58Kg
Z54RDACR6350	Straight Fitting Reduction Ø63mm-Ø50mm
Z54RDACR6340	Straight Fitting Reduction Ø63mm-Ø40mm
Z54RDACR5050	Straight Fitting Ø50mm
Z54RDACR5040	Straight Fitting Reduction Ø50mm-Ø40mm

STRAIGHT FITTINGS Ø40

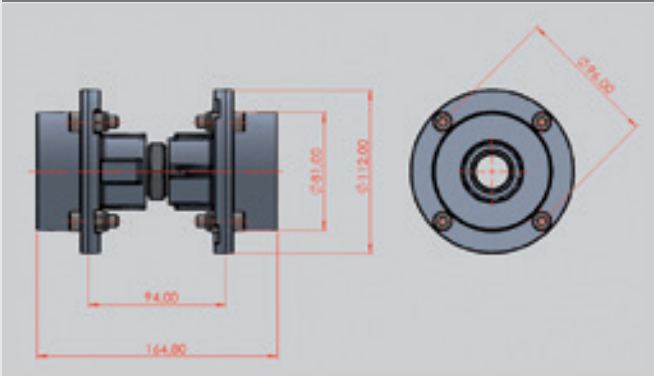

Code	Description
Z54RDACR4040	Straight Fitting Ø40mm - 0,33Kg
Z54RDACR4032	Straight Fitting Reduction Ø40mm-Ø32mm
Z54RDACR4025	Straight Fitting Reduction Ø40mm-Ø25mm
Z54RDACR40RO	Straight Fitting 1x Ø40mm 1x G.1/2" Female
Z54RDACR3232	Straight Fitting Ø32mm
Z54RDACR3225	Straight Fitting Reduction Ø32mm-Ø25mm
Z54RDACR32RO	Straight Fitting 1x Ø32mm 1x G.1/2" Female

STRAIGHT FITTINGS COMPONENTS FOR PIPE (Ø25/Ø20)

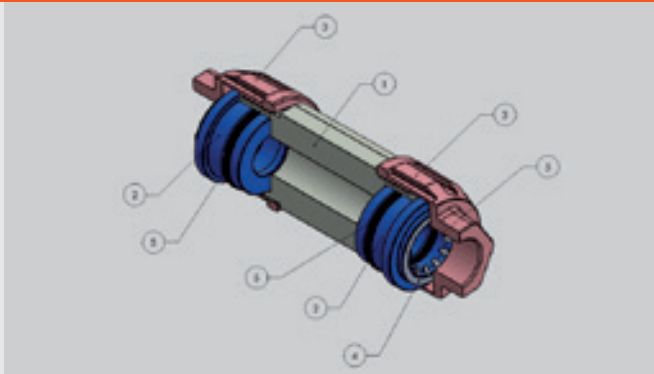

- ① STRAIGHT FITTING - Aluminum
- ② SUPPORTING RING - Aluminum
- ③ THREADED FLANGE - Aluminum
- ④ CLAMPING SPRING - Stainless steel
- ⑤ SEAL - NBR

STRAIGHT FITTINGS Ø25/Ø20

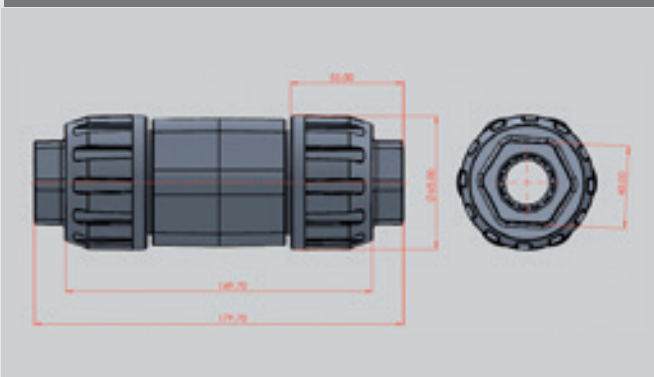

Code	Description
Z54RDACR2020	Straight Fitting Ø20mm
Z54RDACR2525	Straight Fitting Ø25mm
Z54RDACR2520	Straight Fitting Reduction Ø25mm-Ø20mm

COMPRESSED AIR DISTRIBUTION NETWORK FITTINGS COMPONENTS

STRAIGHT FITTINGS Ø25 WITH FEMALE THREAD

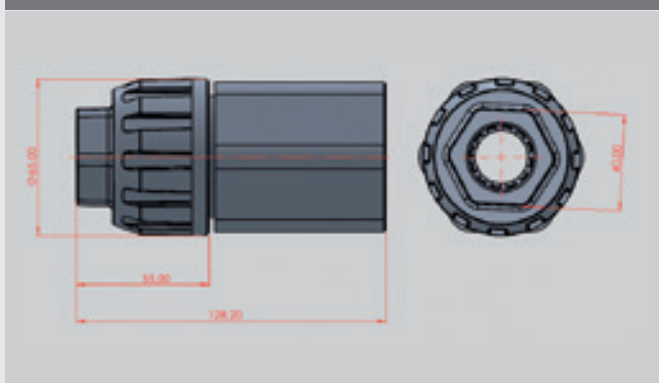

Code	Description
Z54RDACR20RO	Straight Fitting 1x Ø20mm 1x G.1/2" Female
Z54RDACR25RO	Straight Fitting 1x Ø25mm 1x G.3/4" Female

STRAIGHT PIPES

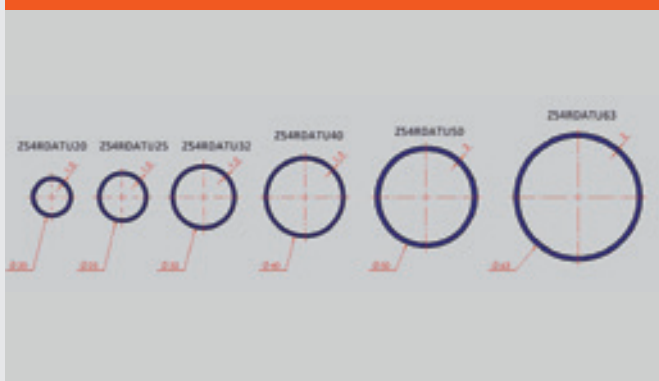

Ø (mm)	Code	Description
63	Z54RDATU63	Straight pipe
50	Z54RDATU50	Straight pipe
40	Z54RDATU40	Straight pipe
32	Z54RDATU32	Straight pipe
25	Z54RDATU25	Straight pipe
20	Z54RDATU20	Straight pipe

- Aluminum pipes
- Exterior painting: Color 2,5 PB 4/10 (safety blue)
- Does not require any type of intervention on the piping such as threads or grooves.
- Bars with a standard length of 6,0 m

CURVED TUBE 180° - Ø20



Ø (mm)	Code	Description
25	Z54RDABE25	Aluminum curved tube

- Aluminum curved tube
- Exterior painting: Color 2,5 PB 4/10 (safety blue)
- Does not require any type of intervention on the piping such as threads or grooves.

CURVED TUBE 180° - Ø20

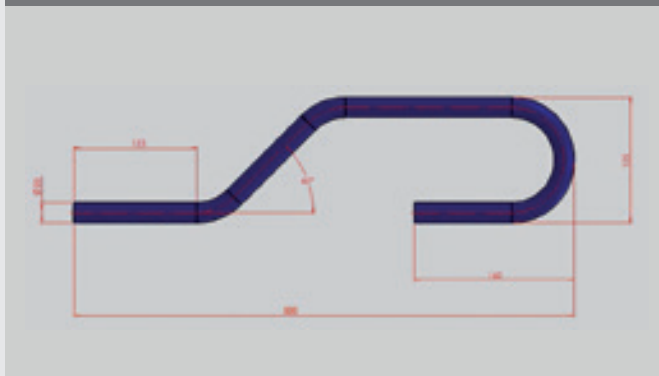

Ø (mm)	Code	Description
20	Z54RDABE20	Aluminum curved tube

- Aluminum curved tube 180°
- Exterior painting: Color 2,5 PB 4/10 (safety blue)
- Does not require any type of intervention on the piping such as threads or grooves.

BYPASS – Ø25

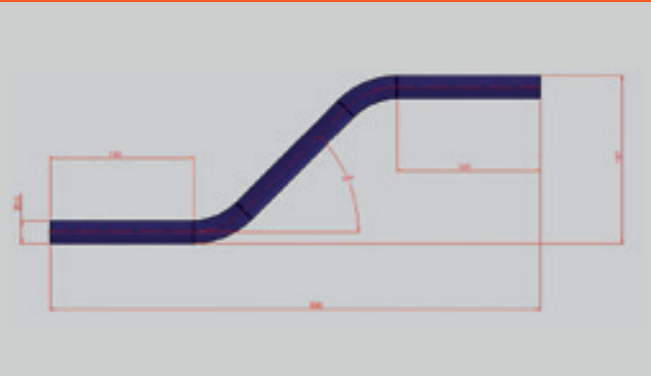

Ø (mm)	Code	Description
25	Z54RDADS25	Aluminum bypass

- Aluminum bypass
- Exterior painting: Color 2,5 PB 4/10 (safety blue)
- Does not require any type of intervention on the piping such as threads or grooves.

BYPASS – Ø20

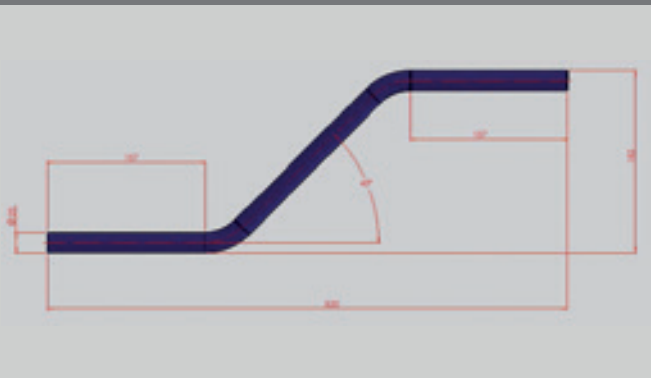

Ø (mm)	Code	Description
20	Z54RDADS20	Aluminum bypass

- Aluminum bypass
- Exterior painting: Color 2,5 PB 4/10 (safety blue)
- Does not require any type of intervention on the piping such as threads or grooves.

FIXING TO BEAMS AND WALLS

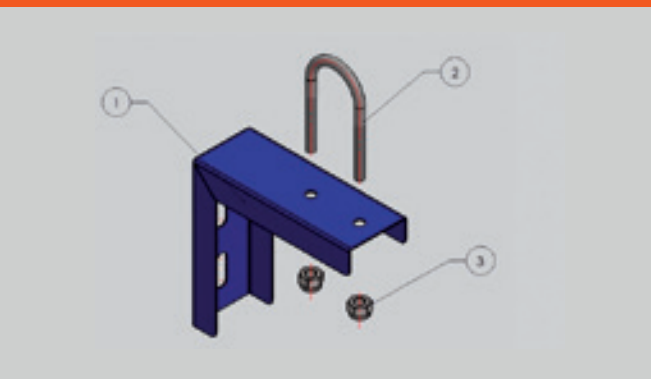

Position	Description
1	Bracket – Steel
2	Type “U” clamp - Steel
3	Nut - Steel

- Bracket according to pipe diameters.
- Fixing the bracket to the masonry, using parabol anchor with Ø3/8”x3.3/4” that comes with the bracket.
- Fixes vertical and horizontal pipes.

FIXING TO BEAMS AND WALLS

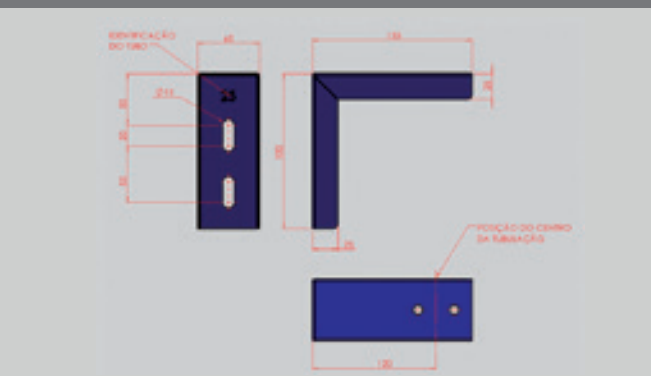

Ø Piping (mm)	Bracket Kit code
Ø63	KRDASUP80063
Ø50	KRDASUP80050
Ø40	KRDASUP80040
Ø32	KRDASUP80032
Ø25	KRDASUP80025
Ø20	KRDASUP80020

- Dimensions for installing the bracket
- The code is already supplied with 2 supports, tie rod and nuts for assembly.

COMPRESSED AIR DISTRIBUTION NETWORK - FIXING COMPONENTS

AERIAL FIXING

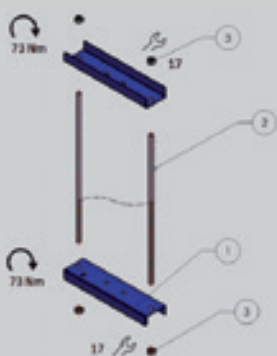

Position	Description
1	Bracket - Steel
2	Tie rod - Steel
3	Nut - Steel

- Standard length of M10 threaded bars of 1,0 m.
- For longer lengths and/or larger bases the company must be contacted.
- Fixes vertical pipes.

AERIAL FIXING

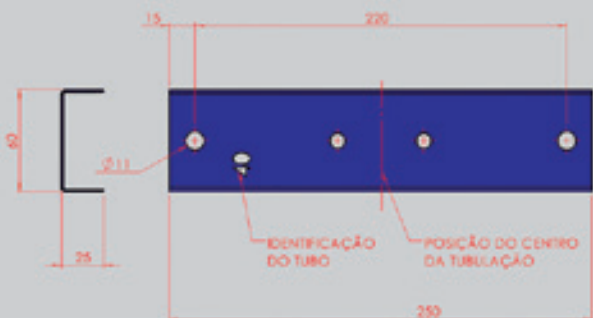

Ø Piping(mm)	Bracket Kit code
Ø63	KRDASUP90063
Ø50	KRDASUP90050
Ø40	KRDASUP90040
Ø32	KRDASUP90032
Ø25	KRDASUP90025
Ø20	KRDASUP90020

- Dimensions for installing the bracket
- The code is already supplied with 2 supports, tie rod and nuts for assembly.

BALL VALVE CONNECTION COMPONENTS (Ø63/Ø50/Ø40 /Ø32 / Ø25)

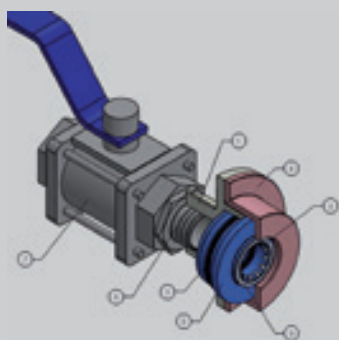

- 1 STRAIGH FITTING - Aluminum
- 2 SUPPORTING RING - Aluminum
- 3 THREADED FLANGE - Aluminum
- 4 CLAMPING SPRING - Stainless steel
- 5 SEAL - NBR
- 6 NIPLÉ - Aluminum
- 7 BALL VALVE - Stainless steel

BALL VALVE CONNECTION COMPONENTS(Ø25 / Ø20)

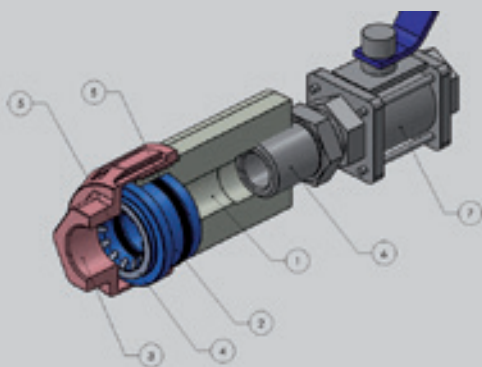

- 1 STRAIGH FITTING - Aluminum
- 2 SUPPORTING RING - Aluminum
- 3 THREADED FLANGE - Aluminum
- 4 CLAMPING SPRING - Stainless steel
- 5 SEAL - NBR
- 6 NIPLÉ - Aluminum
- 7 BALL VALVE - Stainless steel

KRDA6363 – FLANGE FITTINGS Ø63 / PIPE Ø63

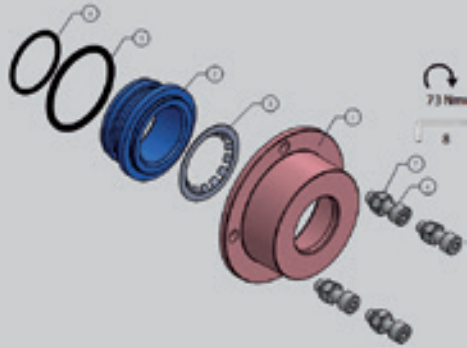

Position	Code	Description	Quantity
1	Z54RDA4006363	Flange Ø63 CT 63	1
2	Z54RDA2006363	Supporting ring Ø63	1
3	RDA3006363	Clamping spring Ø63	1
4	77593082	O Ring	1
5	77593083	O Ring	1
6	700295	Allen screw M10x30	4
7	710005	Self-locking nut M10	4

KRDA6363 – FLANGE FITTINGS Ø63 / PIPE Ø50

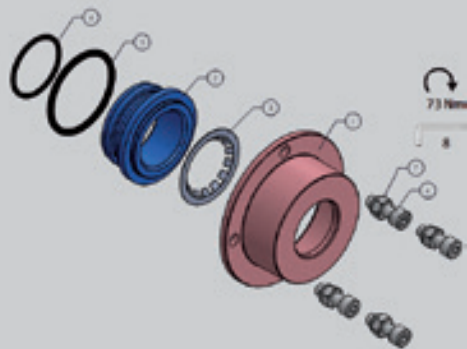

Position	Code	Description	Quantity
1	Z54RDA4006350	Flange Ø50 CT 63	1
2	Z54RDA2006350	Supporting ring Ø50	1
3	RDA3006350	Clamping spring Ø50	1
4	77593082	O Ring	1
5	77593083	O Ring	1
6	700295	Allen screw M10X30	4
7	710005	Self-locking nut M10	4

KRDA6363 – FLANGE FITTINGS Ø63 / PIPE Ø Ø40

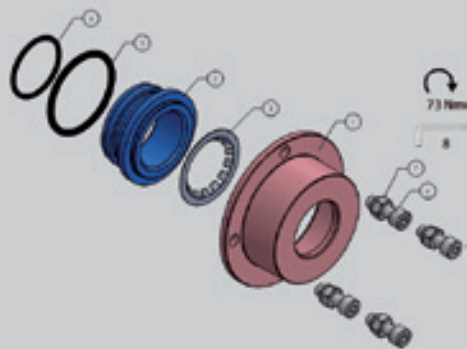

Position	Code	Description	Quantity
1	Z54RDA4006340	Flange Ø40 CT 63	1
2	Z54RDA2006340	Supporting ring Ø40	1
3	RDA3006340	Clamping spring Ø40	1
4	77593082	O Ring	1
5	77593083	O Ring	1
6	700295	Allen screw M10X30	4
7	710005	Self-locking nut M10	4

KRDA6312 – FLANGE FITTINGS Ø63 WITH FEMALE THREAD OUTLET G1/2

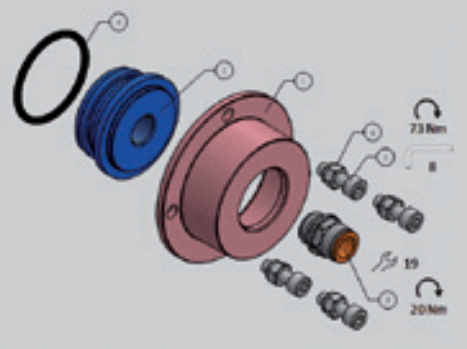

Position	Code	Description	Quantity
1	Z54RDA4006363	Flange Ø63 CT 63	1
2	Z54RDA2006312	Supporting ring G1/2	1
3	2101018	Male cylindrical straight fitting	1
4	77593082	O Ring	1
5	700295	Allen screw M10x30	4
6	710005	Self-locking nut M10	4

Standard configuration for other assembly options in position 3, the company must be contacted.

KRDA4040 – FLANGE FITTINGS Ø40 / PIPE Ø40

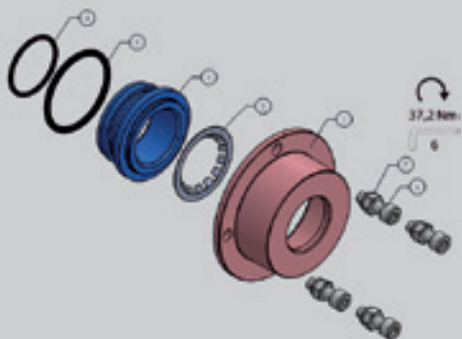

Position	Code	Description	Quantity
1	Z54RDA4004040	Flange Ø40 CT 40	1
2	Z54RDA2004040	Supporting Ring Ø40 C40	1
3	RDA3006340	Clamping Spring Ø40	1
4	77593086	O Ring	1
5	77593085	O Ring	1
6	700288	Allen Screw M8x25	4
7	710025	Self-Locking Nut M8	4

KRDA4032 – FLANGE FITTINGS Ø40 / PIPE Ø32

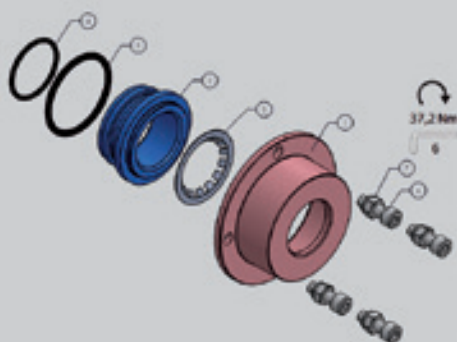

Position	Code	Description	Quantity
1	Z54RDA4004032	Flange Ø32 CT 40	1
2	Z54RDA2004032	Supporting ring Ø32	1
3	RDA3004032	Clamping spring Ø32	1
4	77593086	O Ring	1
5	77593087	O Ring	1
6	700288	Allen screw M8x25	4
7	710025	Self-locking nut M8	4

KRDA4025 – FLANGE FITTINGS Ø40 / PIPE Ø25

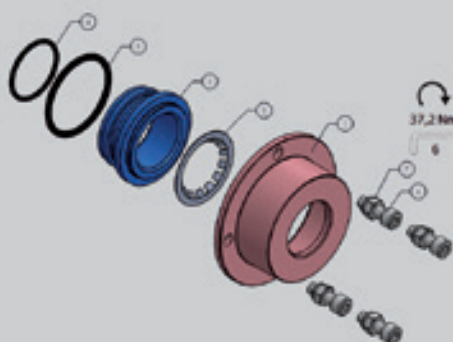

Position	Code	Description	Quantity
1	Z54RDA4004025	Flange Ø25 CT 40	1
2	Z54RDA2004025	Supporting ring Ø25	1
3	RDA3004025	Clamping spring Ø25	1
4	77593086	O Ring	1
5	77593088	O Ring	1
6	700288	Allen screw M8x25	4
7	710025	Self-locking nut M8	4

KRDA4012 – FLANGE FITTINGS Ø40 WITH FEMALE THREAD OUTLET G1/2

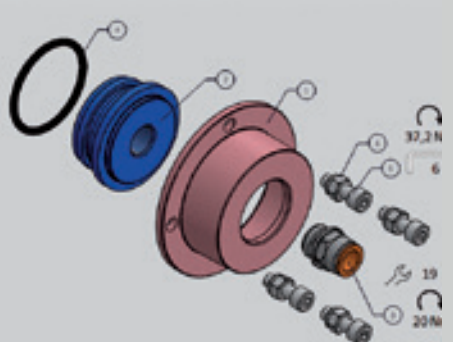

Position	Code	Description	Quantity
1	Z54RDA4004040	Flange Ø40 CT 40	1
2	Z54RDA2004012	Support ring G1/2	1
3	2101018	Male cylindrical straight fitting	1
4	77593086	O Ring	1
5	700288	Allen screw M8x25	4
6	710025	Self-locking nut M8	4

Standard configuration for other assembly options in position 3, the company must be contacted.

KRDA2525 – FLANGE FITTINGS Ø25 / PIPE Ø25

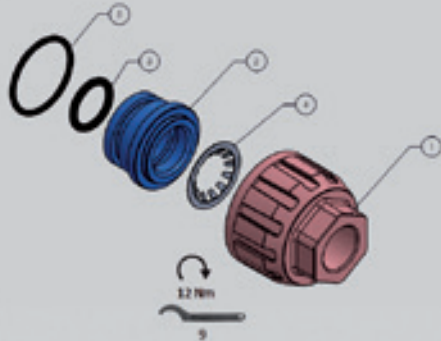

Position	Code	Description	Quantity
1	Z54RDA4002525	Threaded flange Ø25 CT 25	1
2	Z54RDA2002525	Supporting ring Ø25 CT 25	1
3	77593088	O Ring	1
4	RDA3004025	Clamping spring Ø25	1
5	77593089	O Ring	1

KRDA2525 – FLANGE FITTINGS Ø25 / PIPE Ø20

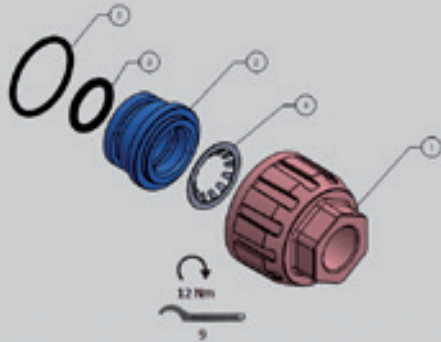

Position	Code	Description	Quantity
1	Z54RDA4002520	Threaded flange Ø20 CT 25	1
2	Z54RDA2002520	Supporting ring Ø20 CT 25	1
3	77593088	O Ring	1
4	RDA3004025	Clamping spring Ø20	1
5	77593089	O Ring	1

KRDA2538 – FLANGE FITTINGS Ø25 WITH FEMALE THREAD OUTLET G3/8

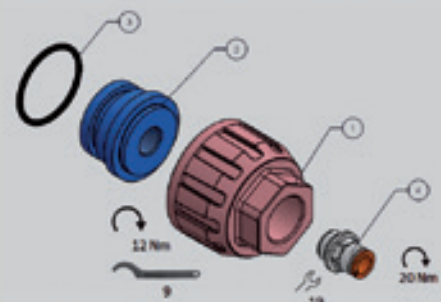

Position	Code	Description	Quantity
1	Z54RDA4002525	Threaded flange Ø25 CT 25	1
2	Z54RDA2002512	Supporting ring G3/8	1
	77593089	O Ring	
	2L01013	Male cylindrical straight fitting	

Standard configuration for other assembly options in position 4, the company must be contacted.

NIPPLE FOR STRAIGHT FITTINGS



Ø Piping (mm)	Ø Fitting (mm)	Code	Description
Ø63	Ø63	RDANP112112	Male Nipple G1.1/2 X G1.1/2
Ø50	Ø63	RDANP112112	Male Nipple G1.1/2 X G1.1/2
Ø40	Ø63	RDANP112112	Male Nipple G1.1/2 X G1.1/2
Ø40	Ø40	RDANP114114	Male Nipple G1.1/4 x G1.1/4
Ø32	Ø40	RDANP114114	Male Nipple G1.1/4 x G1.1/4
Ø25	Ø40	RDANP114114	Male Nipple G1.1/4 x G1.1/4
Ø25	Ø25	RDANP034034	Male Nipple G3/4 X G3/4
Ø20	Ø25	RDANP034034	Male Nipple G3/4 X G3/4

NIPPLE FOR STRAIGHT FITTINGS WITH BALL VALVE



Ø Piping (mm)	Ø Fitting (mm)	Code	Description
Ø63	Ø65	RDANP212212	Male Nipple G1.1/2 X G2.1/2
Ø50	Ø50	RDANP200212	Male Nipple G2 X G1.1/2
Ø40	Ø40	RDANP112212	Male Nipple G1.1/2 X G1.1/2
Ø40	Ø40	RDANP114112	MALE NIPPLE G1.1/4 X G1.1/2
Ø32	Ø40	RDANP114114	Male Nipple G1 X G1.1/4
Ø25	Ø40	RDANP114100	Male Nipple G1 X G1
Ø25	Ø25	RDANP034100	Male Nipple G3/4 X G1
Ø20	Ø20	RDANP034034	Male Nipple G3/4 X G3/4

NIPPLE FOR STRAIGHT FITTINGS WITH BALL VALVE



Ø Piping (mm)	Ø Fitting (mm)	Valve	Description
Ø63	Ø63	S60212G1	Ball valve Ø2.1/2
Ø50	Ø63	S60002G1	Ball valve Ø2
Ø40	Ø63	S60112G1	Ball valve Ø1.1/4
Ø40	Ø40	S60112G1	Ball valve Ø1.1/4
Ø32	Ø40	S60114G1	Ball valve Ø1.1/4
Ø25	Ø40	S60001G1	Ball valve Ø1
Ø25	Ø25	S60001G1	Ball valve Ø1
Ø20	Ø25	S600034G1	Ball valve Ø3/4

ALUMINUM PIPING IDENTIFICATION

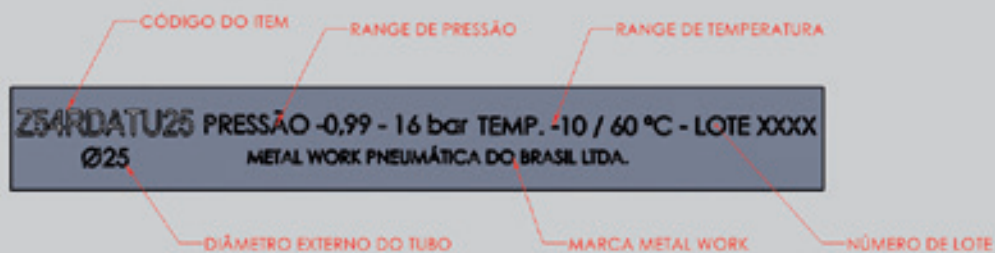

NOTES

ELEMENTS CUTTING

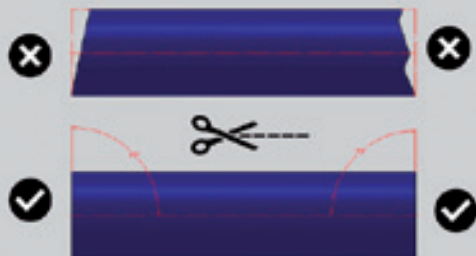

If any pipe needs to be cut, this operation must have a finish free of burrs and sharp edges to avoid damaging the seals and with a chamfer whenever possible, in addition to having a cutting face completely perpendicular to the center line of the item.

PIPES CUTTING

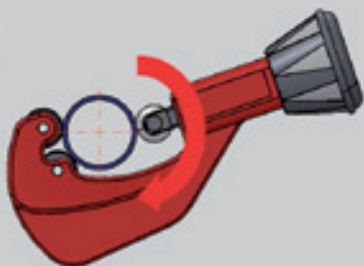

Align the blade with the making of the final dimension of the pipe to be cut, using circular movements.

PIPES CUTTING

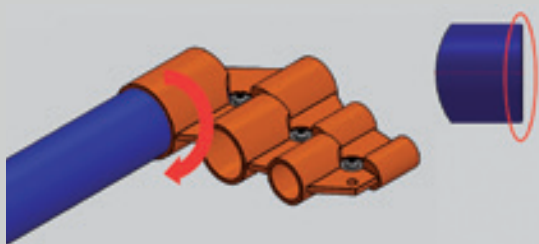

Insert the pipe until it reaches the internal stop of the tool and perform the chamfer, using circular movements.

PIPES CUTTING

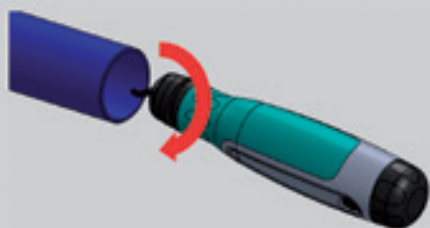

Position the tool and perform deburring, using circular movements.

ASSEMBLY INSTRUCTIONS

FIXING - THE WALL MOUNTING BRACKET IN THE HORIZONTAL POSITION

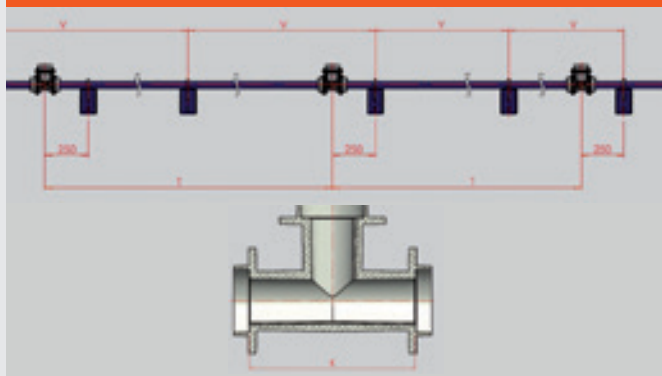

Pipe Ø (mm)	Max. "V" (m)	K (mm)
Ø63	4,5	288
Ø50	4	228
Ø40	3,5	228/138
Ø32	3	138/138
Ø25	2,5	138/138
Ø20	2,5	138

• The dimension "T" considered, consists of the standard length of the pipe (6m), plus the dimension "K" which varies depending on the diameter of the fittings.

FIXING - THE WALL MOUNTING BRACKET IN THE HORIZONTAL POSITION



FIXING - THE WALL MOUNTING BRACKET IN THE VERTICAL POSITION

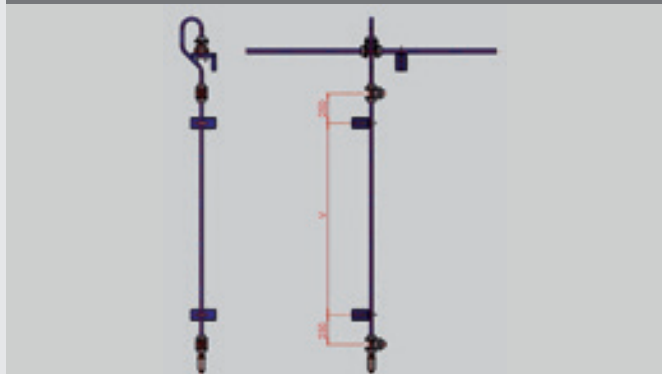

The "V" value must not exceed 3.0 m.

FIXING - DROP BENDS

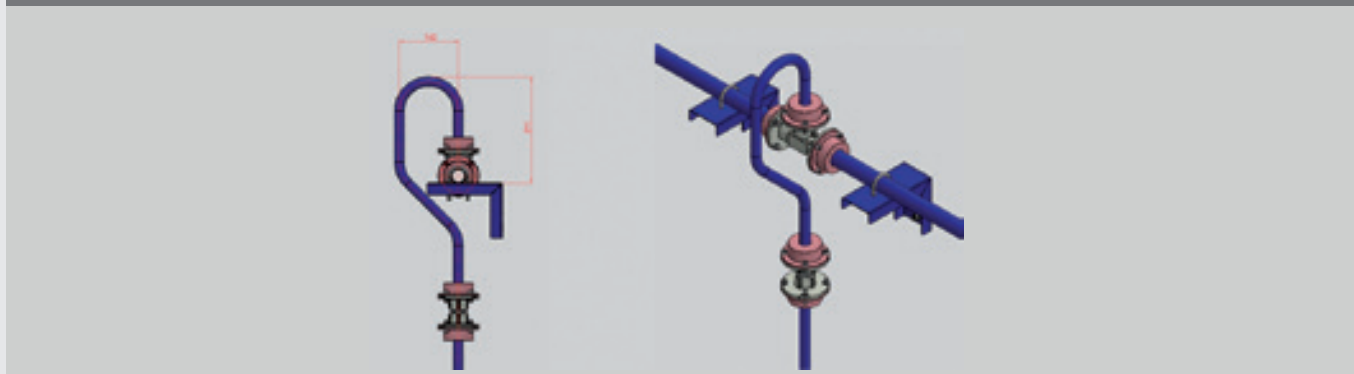

FIXING - ACCESSORIES ASSEMBLY

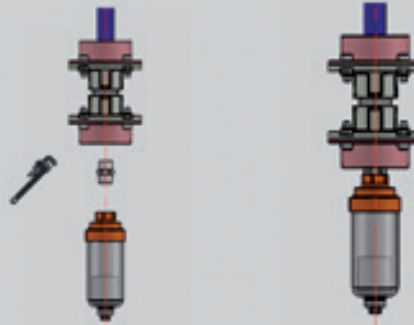

INSTALLATION

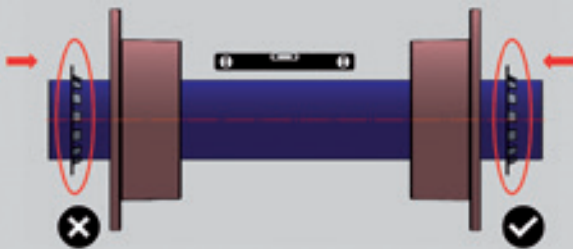

- Always observe the order and position of the elements when installing.

INSTALLATION

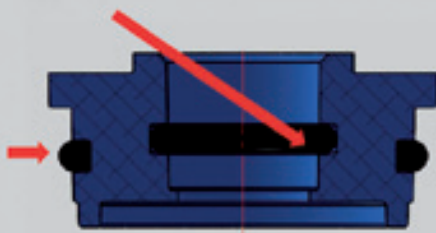

- Apply BERULUB FR16 grease around the fastening elements, as indicated below before assembly.
- In assemblies that use a hose connection, or any other accessory for using compressed air, this must be previously assembled, before inserting the clamping spring into the fitting.

INSTALLATION

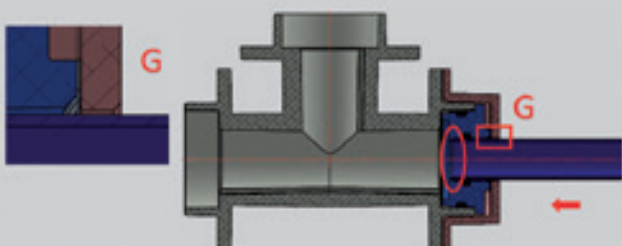

- Introduce the elements.
- Ensure that the pipe is inserted up to the stop as indicated.

FIXING

INSTALLATION

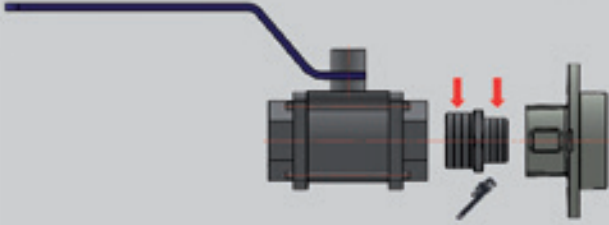

- Coupling components as shown in the imagem on the left.

INSTALLATION

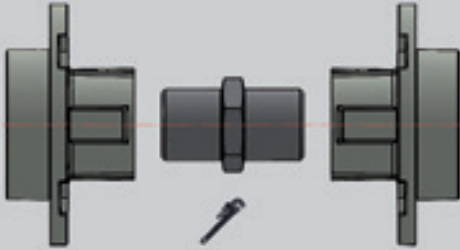

- Coupling components as shown in the imagem on the left.

INSTALLATION

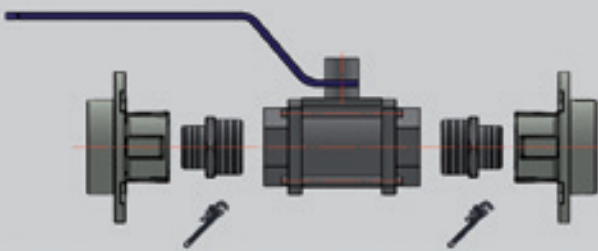

- Coupling components as shown in the imagem on the left.

INSTALLATION

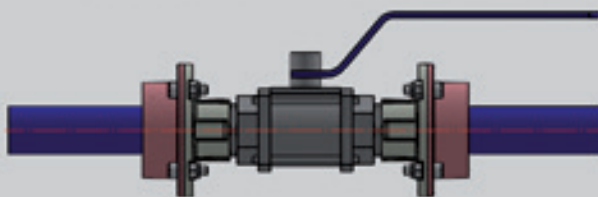

- Accessories assembly.

INSTALLATION

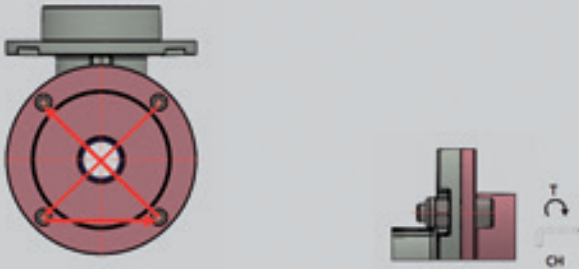

Ø Fitting (mm)	Torque (Nm)
Ø63	T 30-40 / CH 8
Ø40	T 15-25 / CH 6

- To tighten the screws following the triangle and tighten them all equally until the final torque is reached.

INSTALLATION

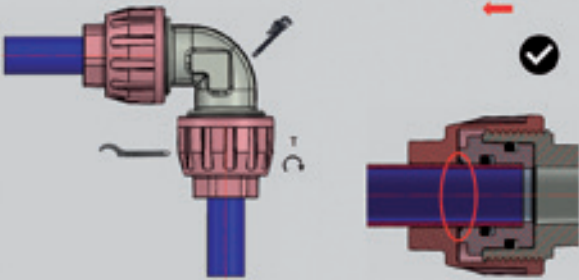

Ø Fitting (mm)	Torque (Nm)
Ø25	12 / HN 09

- To tighten the nut until the final torque is reached.

INSTALLATION

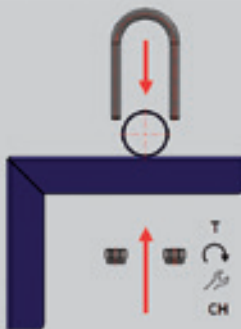

TUBO Ø (mm)	Torque (Nm) / Key
Ø63	T 15-25 / CH 14 A 17
Ø50	T 15-25 / CH 14 A 17
Ø40	T 15-25 / CH 13
Ø32	T 15-25 / CH 13
Ø25	T 15-25 / CH 13
Ø20	T 15-25 / CH 13

- To fix the pipe and tighten the nuts.
- Also applicable to the aerial bracket model (KRASUP800).

NOTES

WARNING AND WARRANTY

WARNING



- Preventive maintenance of screws must be carried out at least once a year with the appropriate records established in the Regulatory Standard number 12 (NR-12).
- Preventive maintenance of seals must be carried out at least once every five years with the appropriate records established in the Regulatory Standard number 12 (NR-12).
- Personal Protective Equipment (PPE's) must be used for both installation and maintenance of the compressed air distribution network.
- All doubts must be solved before starting work, since an inadequate installation creates the risk of ejection of fluid under pressure, which could cause damage to the equipment and/or worker.
- Do not exceed an internal pressure of 16 bar inside the air distribution network.
- Check before installation that there are no missing elements included in this manual. Therefore, the manual must be read in full before starting the installation.
- Metal Work Pneumática do Brasil Ltda is exempt from any responsibility for any type of damage caused to property, people, animals which may have been caused by inadequate installation of the equipment.

WARRANTY TERM



- The product has a full warranty against any and type of failure or manufacturing problems.
- The warranty does not cover problems and/or damages caused by improper transportation or storage of the product..
- The product warranty does not cover pressure ranges, temperatures or corrosion resistance degrees other than those specified throughout this manual.
- The product warranty does not cover failures and/or problems caused by improperty installation or use of product.
- The warranty does not apply if inappropriate fluid is used for the product.



METAL WORK PNEUMÁTICA DO BRASIL LTDA
Rua Otacílio Jacinto Homem, 415 - Bairro Scharlau
São Leopoldo/RS - CEP 93.120-590
Tel./WhatsApp: 55 51 3590.7100
metalwork@metalwork.com.br

FILIAL SÃO PAULO
Rua Alferes Magalhães, 92 - Sala 11 - Bairro Santana
São Paulo/SP - CEP 02.034-006
Tel.: 55 11 2099.3623
WhatsApp: 55 11 95312.1631

www.metalwork.com.br