

ELECTRIC CYLINDER SERIES ELEKTRO ISO 15552 EK WITH DIRECT CURRENT MOTOR



Electric cylinders in the ELEKTRO ISO 15552 EK series (with ISO 15552 interface) can also be supplied with a DC motor for simplified control of the movement and reduced costs in terms of product and management system at the same time.

For the new line with DC motors, the forward movement of the piston rod can be obtained either with a trapezoidal screw and nut or a multi-start screw and nut.

The cylinder incorporates an anti-rotation system obtained from two engineering polymer pads that run in the special slots inside the cylinder liner. On request, a version without anti-rotation is also available.

The piston comes complete with a magnet and the liner has slots for mounting magnetic sensors.

A system for greasing the screw/nut is included.

The motor supplied is ready equipped with an incorporated gearbox, it is axially connected to the cylinder and includes a pair of "Hall" sensors for possible position control.

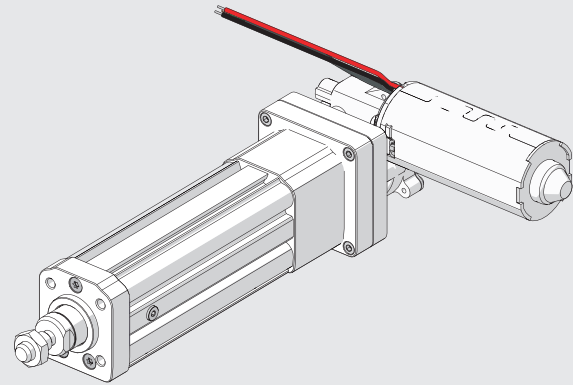

TECHNICAL DATA		Lead screw	Trapezoidal screw
Screw pitch	mm	5	4
Screw diameter	mm	12	14
Piston rod thread		Male, M10x1.25	
Ambient temperature	°C	0 ÷ 40	
Degree of protection with motor mounted		IP40	
Minimum stroke	mm	At least 2 times the screw pitch	
Maximum stroke	mm	500	
Versions		In line, with or without anti-rotation of the piston rod	
Uncontrolled impact at the end of stroke		NOT ALLOWED (it provides an extra-stroke minimum 5 mm)	
Sensor magnet		YES	
Work position		Any	
Duty Cycle		20% **	
Motor		Direct current DC	
Supply voltage	VDC	24	
Input power with MAX torque	W	48	
Input current with MAX torque	A	2	
Max axial load	N	See graphic on next page	
Maximum speed	mm/s	See graphic on next page	
Maximum load in vertical position and motor powered off (reversibility)	N	100	Irreversible (max recommended 1000)
Interference suppression		Circuito LC	
Direction of rotation		According to polarity	
Encoder		Two-channel, three motor pulses/revolution per channel, NPN.	
Resolution	mm/imp.	0.085	0.068

** maximum motor temperature, measured on the outer surface, must NOT exceed 70°C

CYLINDER CONNECTION AND WIRING DIAGRAM

WITH ENCODER

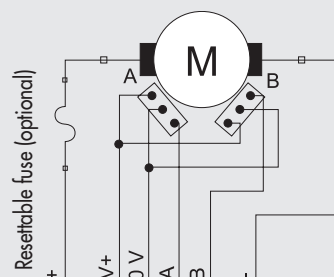

Function	Corresponding wire colour
Motor power supply +	Red
Motor power supply -	Blue
ENCODER Power supply + V+ 5 ÷ 20 VDC	Brown
Encoder 0 V supply	White
Encoder channel A (NPN)	Green
Encoder channel B (NPN)	Yellow

Please contact our sales offices for further information and quotation.

DIMENSIONS

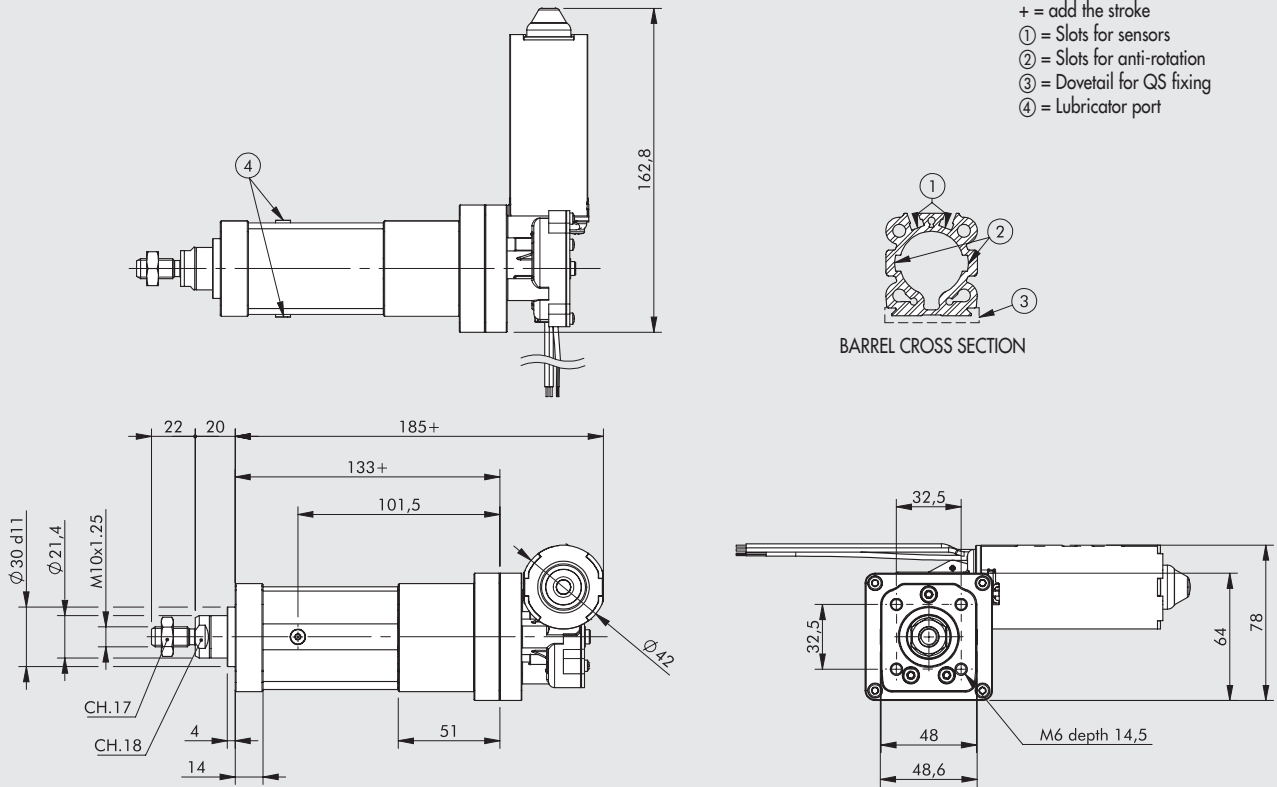

- + = add the stroke
- ① = Slots for sensors
- ② = Slots for anti-rotation
- ③ = Dovetail for QS fixing
- ④ = Lubricator port

AXIAL LOAD CURVES AS A FUNCTION OF SPEED

Ø32 with gearmotor CC 1/19.67 24VDC / max 2A

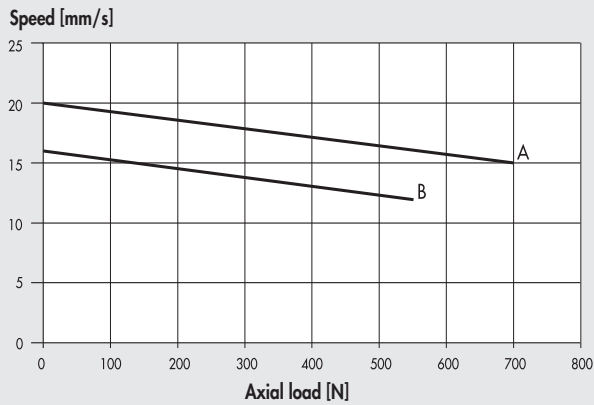

- A = with trapezoidal screw 14x4
- B = with lead screw 12x5

ACCESSORIES

The accessories of the ELEKTRO ISO 15552 EK series electric cylinders can be used, with the exception of the rear clamps.